

# ALPOLIC™

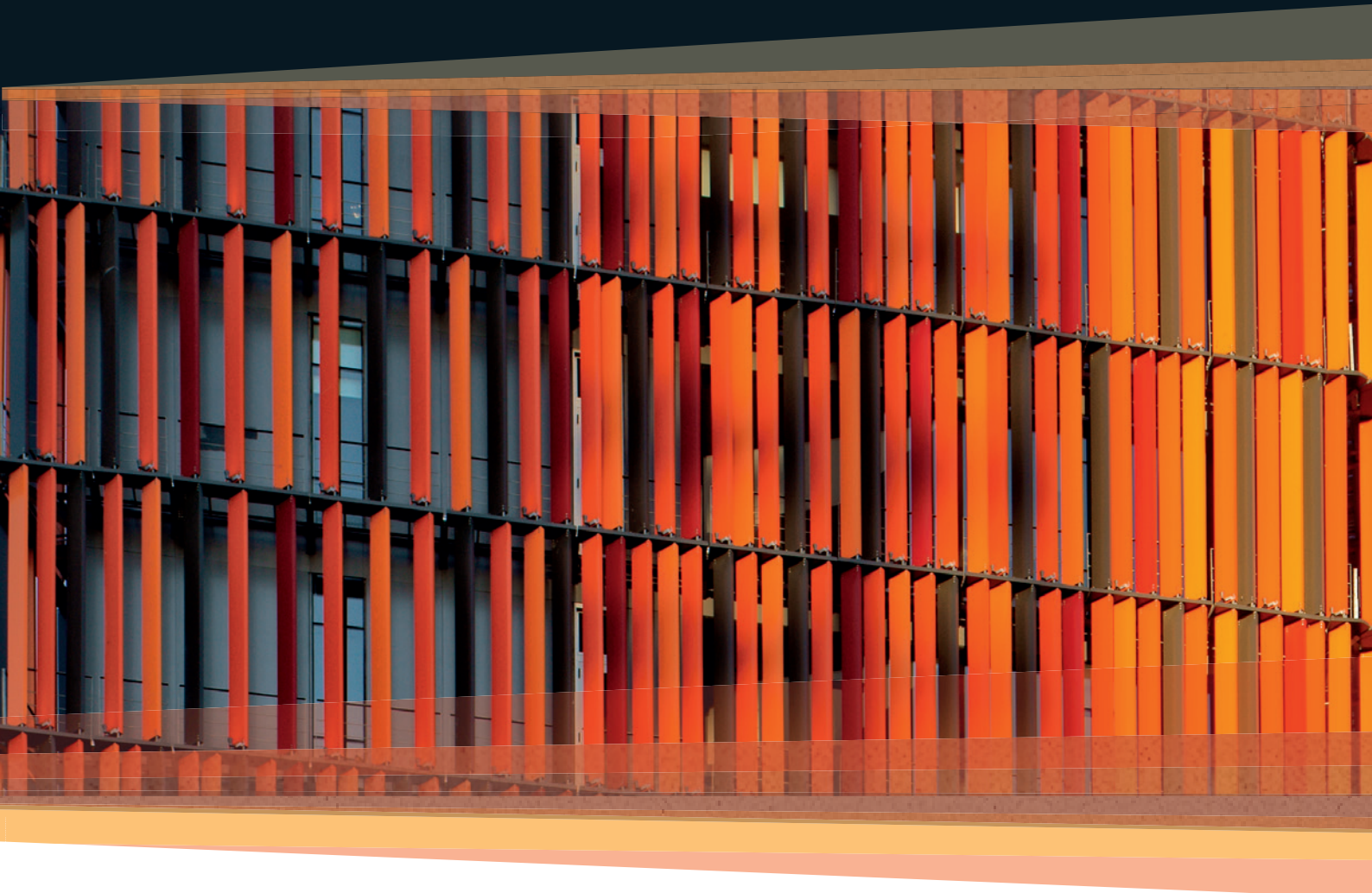

## FABRICATION MANUAL

 MITSUBISHI POLYESTER FILM

# CONTENTS

## GENERAL

Product information	4
Technical data	5

## HANDLING, TRANSPORTATION, STORAGE

General	6
Reflective direction, protective film	7

## JOINTING AND FIXING TECHNIQUE

General	8
Cassette systems	9
Riveting system	10
Screwing on wood substructures	12
Edge distances, thermal expansion	13

## PROCESSING METHODS

Tools, machines	14
Trimming of cut edges	15
Grooving, Routing	16
Groove shapes, folding	17
Bending	18
Cassette systems	20
Folding of cassette systems	21
Perforated panels	22

## CLEANING

General	23
---------	----

**ALPOLIC™ – high-quality aluminium composite panels for architecture**

ALPOLIC™ is a brand of the Mitsubishi Chemical Corporation and has been setting trends and standards for building architecture with its exceptional quality products for more than 45 years. ALPOLIC™ aluminium composite panels consist of two aluminium sheets which are applied to a mineral core. They are manufactured in a coilcoating process using the most stringent safety and requirements. These are the only panels in the industry that are almost 100% recyclable. In terms of fire protection they provide the maximum safety. Even the standard design ALPOLIC™ /fr complies with the fire protection classification Euroclass B, s1, d0 (flame retardant). Optionally, the products are also available as a non-combustible variant ALPOLIC™ A2 that complies with the Euroclass A2-s1, d0 (non-combustible) fire protection classification.

Compared to aluminium panels, the ALPOLIC™ aluminium composite panels are lighter, sturdier, flatter and easier to process. Moreover, the following properties are just some of those that set them apart:

- High-quality surface coating with LUMIFLON™
- Up to 20 years quality guarantee
- Extensive range of colours and designs
- Rear side with primer base coat coating
- Consistent colour quality and consistency
- Excellent flatness
- Easy to process
- High rigidity

ALPOLIC™ composite panels are manufactured by Mitsubishi Chemical Corporation in Germany, Japan and the USA and are only distributed by authorised specialist dealers.

COMPOSITION

ALPOLIC™/fr

ALPOLIC™ A2

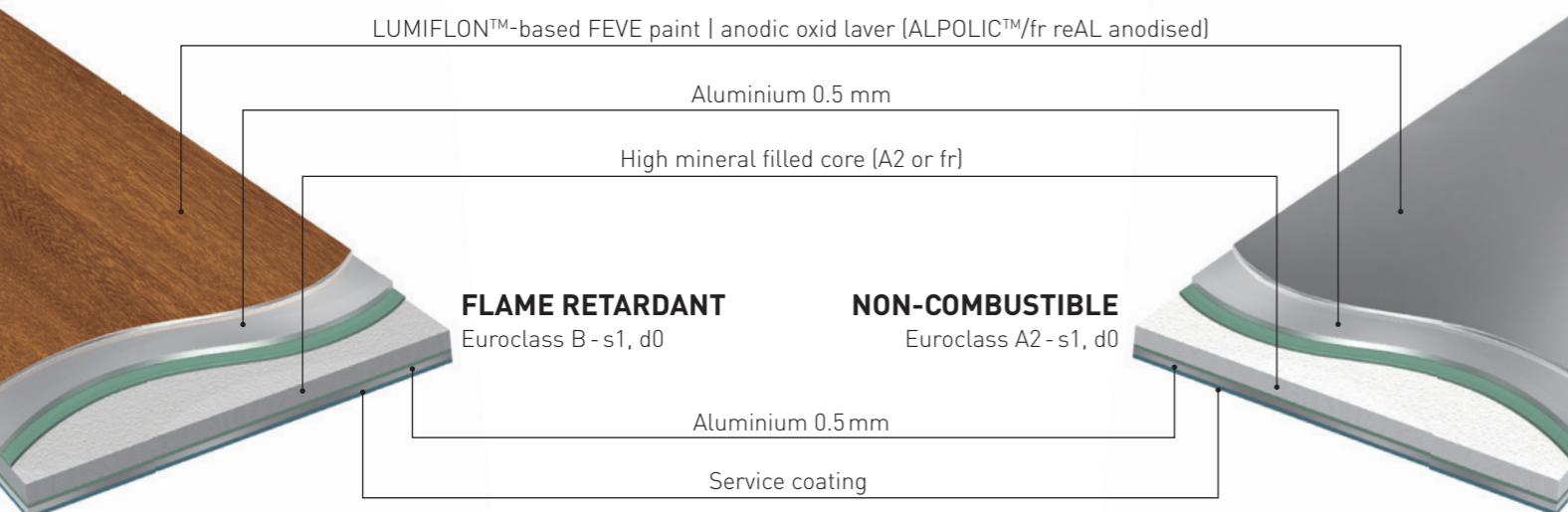

Total Thickness: 3, 4 and 6 mm

Total Thickness: 4 mm

**ALPOLIC™/fr: aluminium composite panels, fire-retardant**

ALPOLIC™/fr aluminium composite panels comprising two 0.5 mm thick aluminium panels and a **fire-retardant**, mineral polymer core (FR). The total thickness is 3, 4 or 6 mm. The front side is coated with a high-quality LUMIFLON™-based fluoropolymer paint (FEVE) and covered with a removable protective film. The rear side is coated with a primer base coat.

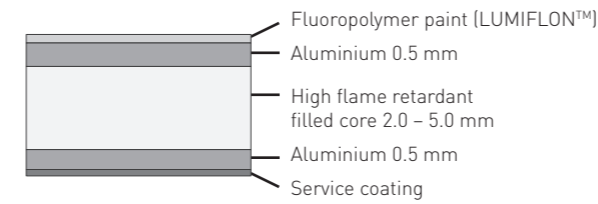

Total thickness: 3, 4 or 6 mm

**ALPOLIC™ A2: aluminium composite panels, non-combustible**

ALPOLIC™ A2 aluminium composite panels comprising two 0.5 mm thick aluminium panels with a **non-combustible**, mineral polymer core (A2). The total thickness is 4 mm. The front side is coated with a high-quality LUMIFLON™-based fluoropolymer paint (FEVE) and covered with a removable protective film. The rear side is coated with a primer base coat.

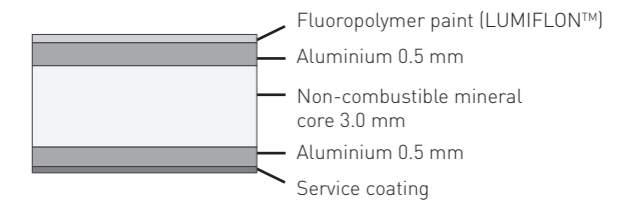

Total thickness: 4 mm

**Dimensional tolerances of ALPOLIC™ aluminium composite panels:**

<b>Width</b>	± 2.0 mm
<b>Length</b>	± 4.0 mm
<b>Thickness</b>	± 0.2 mm in 3 and 4 mm thick, ± 0.3 mm and 6 mm thick
<b>Bow</b>	Maximum 0.5 % (5 mm/m) of the length or width
<b>Diagonal difference</b>	Maximum 5.0 mm

Dimensions	Standard	Unit	Value
Total Thickness	-	mm	3*/4/6
Cover sheet thickness	-	mm	0.5
Core thickness	-	mm	2/3/5
Width	-	mm	1,285/1,535/2,050
<b>Technological values</b>			
Weight	-	Kg/m <sup>2</sup>	6.0/7.6/10.9
Tensile strength	ASTM E8	N/mm <sup>2</sup>	49/29
0.2% proof stress	ASTM E8	N/mm <sup>2</sup>	44/26
Elongation	ASTM E8	%	5/2
Flexural elasticity, E	ASTM D393	kN/mm <sup>2</sup>	39.8/29.1
Deflection temperature	ISO 75-2	°C	116/109
Thermal expansion	ASTM D696	x 10 <sup>-2</sup> /°C	24
<b>Surface</b>			
Coil coating	-	-	LUMIFLON™ -based fluoropolymer coating
Aluminium alloy	-	-	3105-H14/3005-H14/5005A
Gloss (60°)	ASTM D523	%	15 – 80
Pencil hardness	-	-	H

Dimensions	Standard	Unit	Value
Total Thickness	-	mm	4
Cover sheet thickness	-	mm	0.5
Core thickness	-	mm	3
Width	-	mm	1,250/1,500/2,015
<b>Technological values</b>			
Weight	-	Kg/m <sup>2</sup>	8.4
Tensile strength	ASTM E8	N/mm <sup>2</sup>	43
0.2% proof stress	ASTM E8	N/mm <sup>2</sup>	41
Elongation	ASTM E8	%	3.8
Flexural elasticity, E	ASTM D393	kN/mm <sup>2</sup>	38.5
Deflection temperature	ISO 75-2	°C	110
Thermal expansion	ASTM D696	x 10 <sup>-2</sup> /°C	19
<b>Surface</b>			
Coil coating	-	-	LUMIFLON™ -based fluoropolymer coating
Aluminium alloy	-	-	3105-H14/3005-H14/5005A
Gloss (60°)	ASTM D523	%	15 – 80
Pencil hardness	-	-	H

\*3mm does not correspond with the General Construction Regulation DIBt, Berlin

In order to protect ALPOLIC™ A2 and ALPOLIC™ /fr against mechanical damages caused by transport, storage or handling, the following precautions must be noted.

### Handling

- When unpacking and repacking the panels, they should be handled in a clean place.
- When stacking or packing the panels, nothing should be put between them to avoid markings on their surfaces.
- When processing the panels, they should be handled on not the floor but a work table.
- When carrying the panels, they should always be handled by two people. Carry the panels vertically.
- When fabricating the panels, nothing should be put on the work table or the machine's bed.
- Do not stick, put or apply PVC tapes, polyurethane sealant or modified silicone sealant onto the protective film to avoid damaging the panel surface.

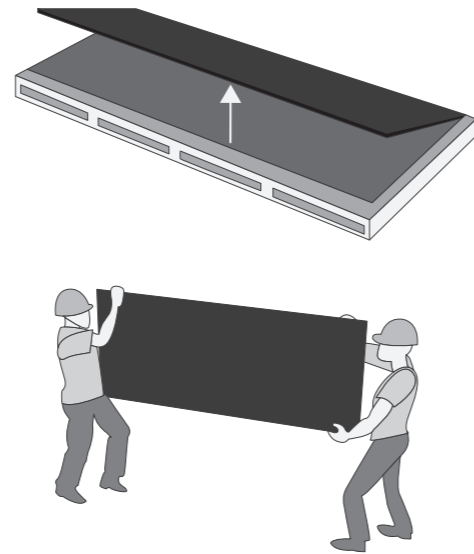

### Transport

- The pallets should be taken into consideration for any damage.
- Mark "Handle with Care", "Keep Dry", "No Hooks" and "This Side Up" clearly on the surfaces of the packed panels.
- Lay the packed panels horizontally and do not place heavy goods on them.

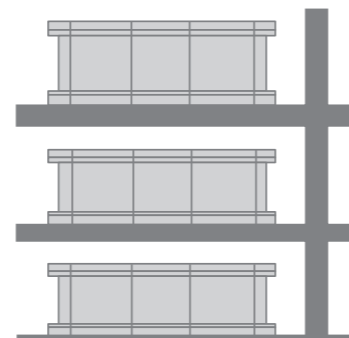

Flat rack

### Storage

- The panels must be stored indoor and in dry atmosphere to minimize the natural-degradation of the protective film by moisture and direct sunlight.
- When storing in a flat rack system, pile up the same size of panels on a rigid palette. Do not pile up different sizes together. Our wooden crates can usually be stacked up to four crates high.
- When storing in a vertical rack system, lean panels closely against an inclined backing material within 10°. The total thickness of leaning panels should not exceed 100 mm thick. Use veneer for backing cover and place rubber mat on the bottom. Avoid scratches when pulling out from the rack and restoring it.

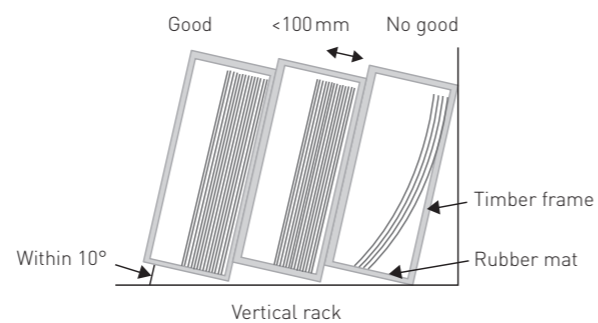

### Contact with other materials

If ALPOLIC™ composite panels come into direct contact with heavy metals (e.g. copper, iron), there is an increased risk of corrosion. When used outdoors, it is essential to observe the correct material separation.

### Horizontal direction

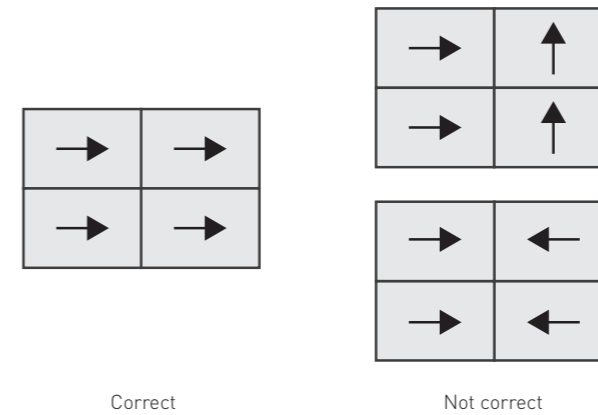

### Vertical direction

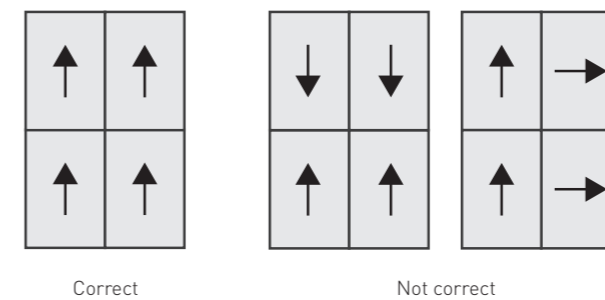

### Reflective direction

Direction arrows are indicated on the protective film of the ALPOLIC™ composite panels which specify the reflective direction.

- Pay attention to the reflective direction so that no difference in brightness occurs in the overall surface when several panels are arranged on the same level.
- In the case of composite panels with a granite or marble design, the reflective direction must be broken so that the pattern is not repeated. To do so, turn the respective following composite panel by 90°.

### Processing notes

- Check the ALPOLIC™ composite panels for possible damage and deformation immediately after unpacking.
- The composite panels always have a punched edge due to the production process. The aluminium is pushed in on this edge.
- The panels must be trimmed as follows:
  - on all sides in order to guarantee the perpendicularity and cleanly cut edges when open cut edges are used
  - on three sides in order to guarantee the perpendicularity for further processing

### Protective film

- The batch number is printed on the rear side. If processing has rendered the imprint illegible, relabel the panel accordingly to ensure traceability.
- Leave the protective film on the composite panel for as long as possible to prevent damage.
- The protective film must be removed immediately after assembly.
- In the case of cassette production, it is recommended to remove the film in the area of the fixing element in the factory.
- When the composite panels are attached outdoors, remove the protective film at the latest after 20 days in order to guarantee residue-free removal.

### Panel direction

In Metallic Colors, Sparkling Colors, Prismatic Colors and Patterns (Stone, Timber, Metal, and Abstract), slight color differences will be noticeable if the panels are installed in different directions (like Panel A and B in the diagram). Install panels in the same direction as marked on the protective film. As for Solid Colors, any color difference due to coating direction is negligible. There may be colour differences when panels from different batches are used.

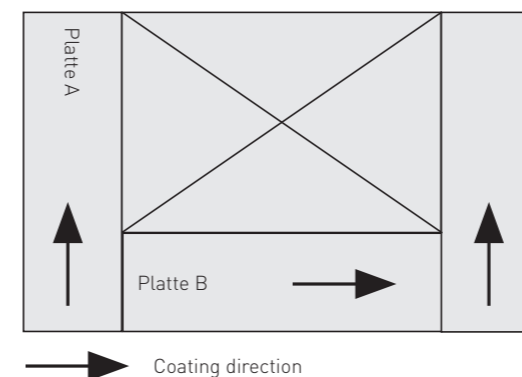

Examples of ALPOLIC™ facade fixing systems

Rivet/Face Fixed System



cassette system (horizontal)



cassette system (vertical)

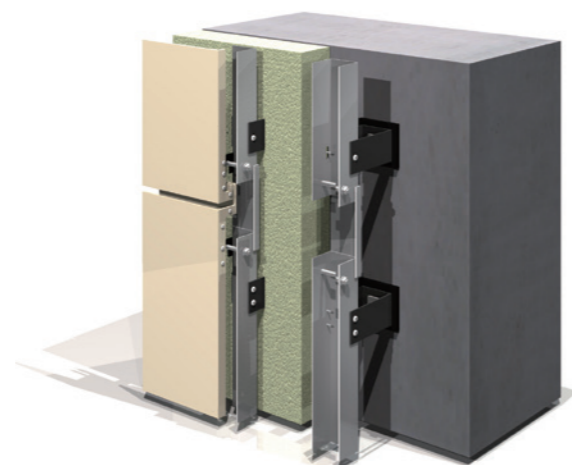

Suspension in bolts and plastic sleeve

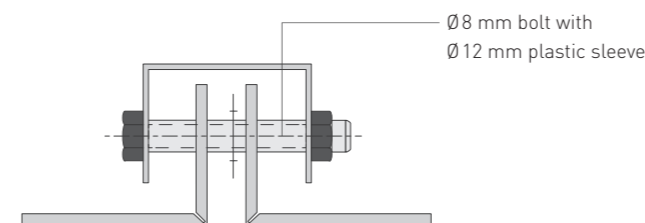

Suspension in bolts

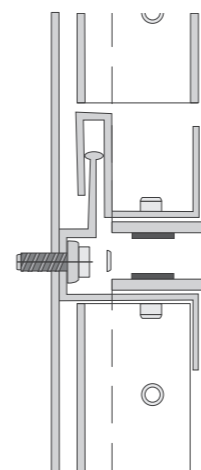
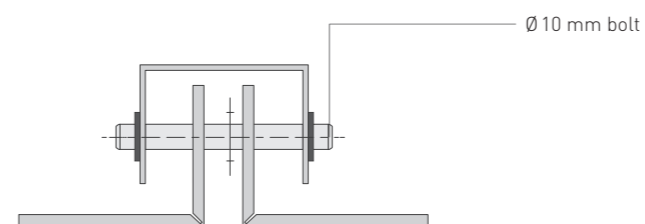

Cassette systems vertical

The cassettes must be fastened at the longitudinal edges by means of the following subframe on bolts: ALPOLIC™ panels with an aluminium sheet thickness of 3 mm

Bolts

- The bolts suspending the above materials are specified as follows:
- Ø 8 mm bolts made of A4 stainless steel with Ø 12 x 1.9 Nylon (PA66) sleeves
  - Ø 10 mm bolts made of A4 stainless steel without sleeves

Corner connector

- The following materials have to be used as the corner connector of the cassettes:
- ALPOLIC™ panels
  - Aluminium sheet with a thickness of at least 2 mm

Blind rivets

For fastening the ALPOLIC™ panels to the above connector, the following blind rivet must be used:

Aluminium blind rivet with Ø5 mm with Ø11, Ø14 or Ø16 mm stainless steel mandrel shaft

Supplier:

- Gesipa / SFS
- MBE GmbH
- Ipex GmbH

Cassette systems horizontal

The cassettes are laid in a horizontal format (HC system). The system-specific aluminium profiles riveted onto the top and bottom horizontal edges of the cassettes are interlocked. Plastic anti-vibration elements are placed at specific points between the profiles. The top HC Z profile and the HC basic profile are generally either riveted at two points or fastened onto the HC hat profile with thread-forming screws and drill screws made of stainless steel.

Please ask us for the detail drawings.

## Substructures

The support profiles of the substructures for the Rivet System must be aluminum profiles with a thickness of at least 2.0 mm with a tensile strength  $R_m \geq 245 \text{ N/mm}^2$  and an elastic limit  $RP 0.2 \geq 200 \text{ N/mm}^2$  [alloy EN AW-6063 T66 in accordance with DIN EN 755-2].

## Specifications for riveted systems

Following details are specified in riveted systems.

## Fixed and sliding points

When attaching ALPOLIC™ composite panels, ensure that there is sufficient allowance for expansion and create fixed and sliding points.

## Fixed points

Take into account at least one fixed point.

Ø Borehole	Ø Rivet
5.1 mm	5.0 mm

## Sliding points

Depending on the size of the composite panels, you will need an appropriate number of sliding points.

Ø Borehole	Ø Rivet
7.5 mm/8.5 mm/9.5 mm	5.0 mm

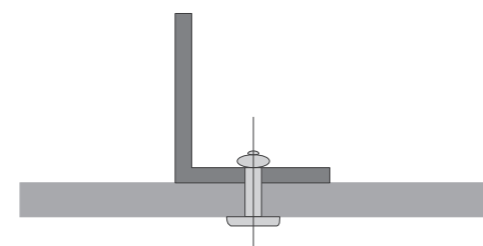
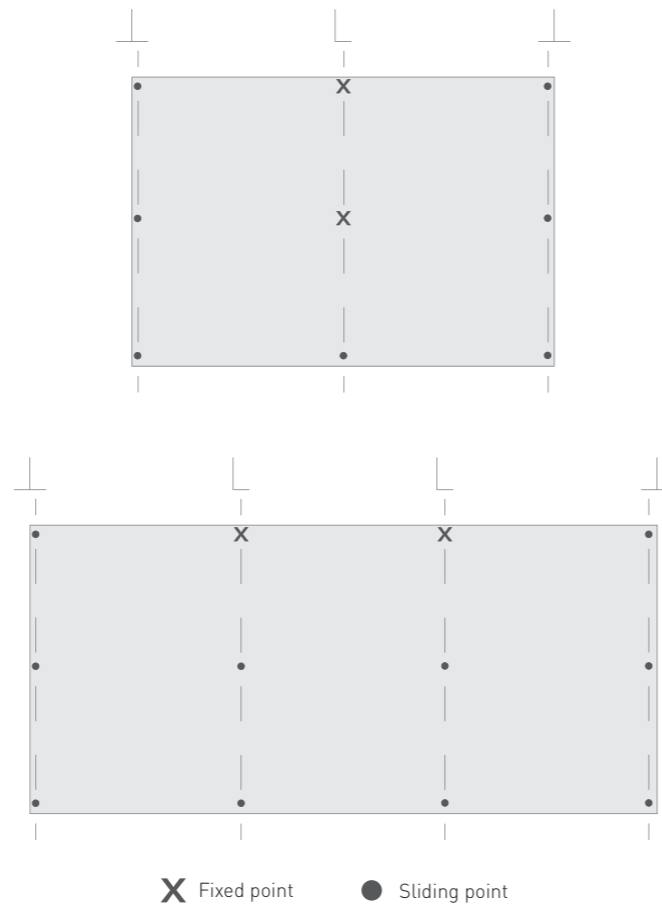

X Fixed point

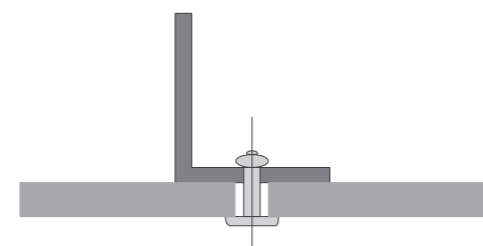

● Sliding point

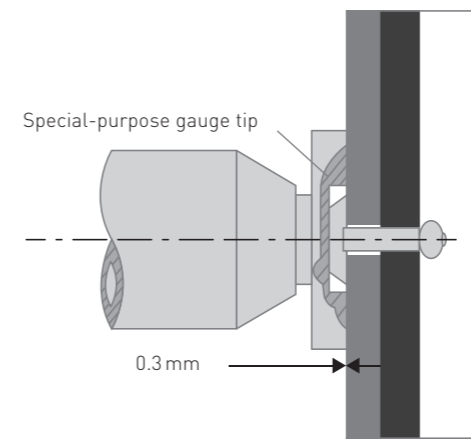

The rivets must be placed using a rivet gauge with a play of 0.3 mm

## Blind rivets

For fastening the ALPOLIC™ panels to the above connector, the following blind rivet must be used:

Aluminium blind rivet with  $\varnothing 5 \text{ mm}$  with  $\varnothing 11$ ,  $\varnothing 14$  or  $\varnothing 16 \text{ mm}$  stainless steel mandrel shaft

Supplier:

- Gesipa / SFS
- MBE GmbH
- Ipex GmbH

## Installation of riveted system

ALPOLIC™ panels can be fastened to the substructure by the blind rivet. To prevent tension from occurring at the riveted point, following techniques are specified.

## Riveting

Note: To avoid galvanic corrosion on ALPOLIC™ composite panels, all rivets, screws or nuts used for the connection must be made of aluminium or stainless steel. If the composite panels are made of dissimilar materials such as steel, ensure that there is material separation.

## Processing information

- A special rivet attachment jig is used for making space over 0.3 mm thick between the rivet flange and the panel.
- Use only approved rivets with a washer head
- Remove the protective film before riveting.
- Observe the borehole sizes and fixed and sliding points specified in the chapter "JOINTING AND FIXING TECHNIQUE", page 8.

## Drilling

The blind rivets must be fastened at the center of the panel holes. A drilling jig is used for centrally drilling holes into the panel and the substructure.

# JOINTING AND FIXING TECHNIQUE

## Screwing on wood substratures

## Edge distances, thermal expansion

### Sliding and fixed points for the screw attachment on a wood substructure

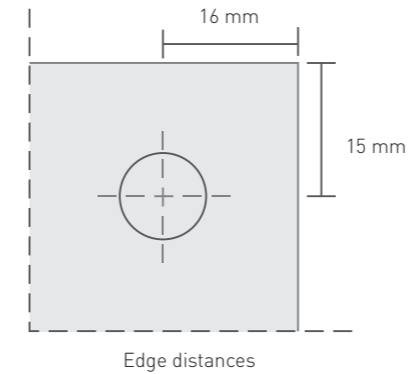
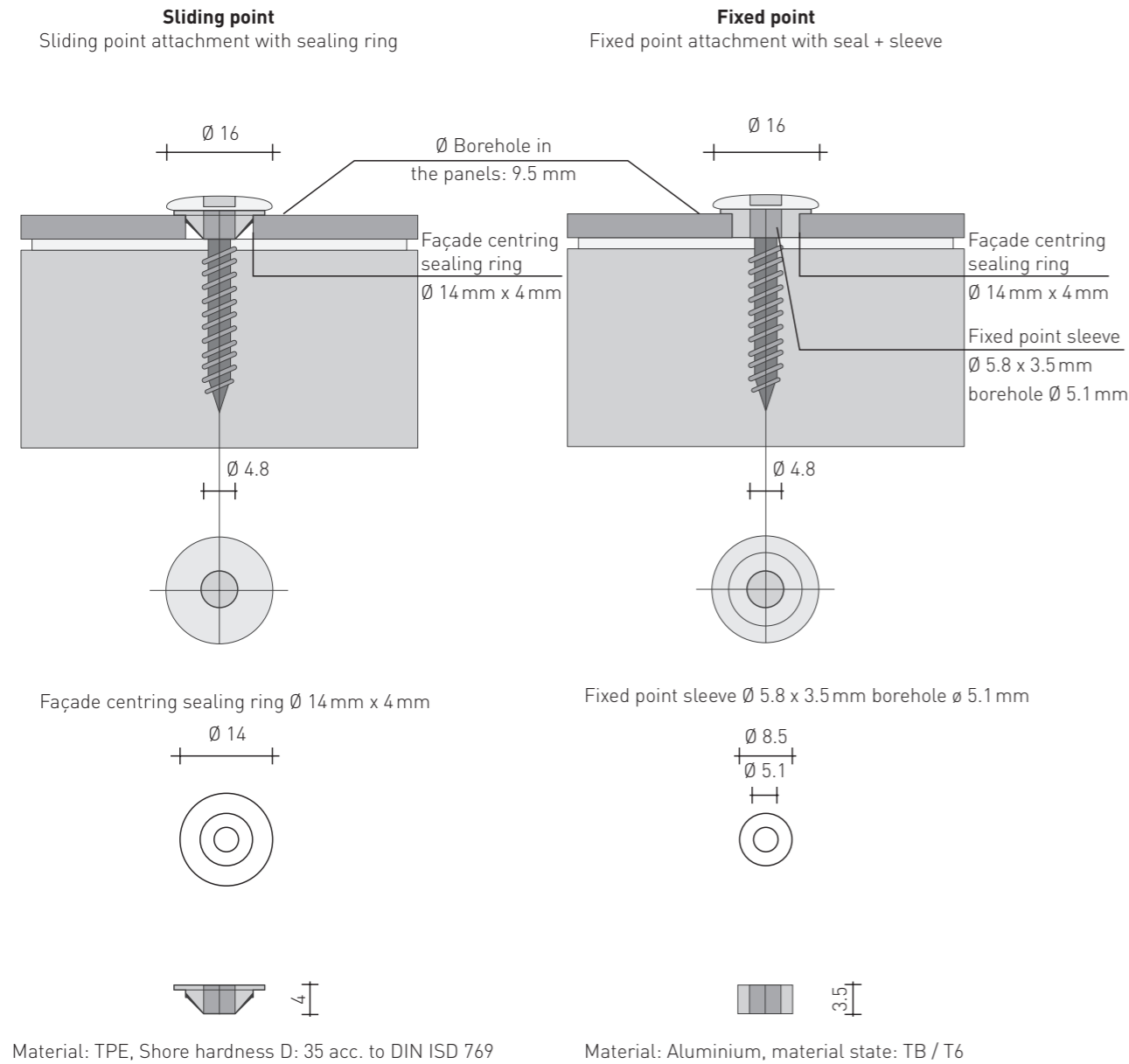

### Distance from the edges

The distance from the rivet to the panel edges must be at least 16 mm.

### Panel gaps

The width of the gaps between the panels must be limited to max. 20 mm.

### Thermal expansion and contraction

The influence of thermal expansion on all the components of each facade system must be considered. For examples, in riveted system, the expected thermal expansion has to be absorbed at each riveted point with the specified diameters.

### Linear thermal expansion coefficient

Material	Linear thermal expansion coefficient, 1/°C	Expansion per 1 meter with 50 °C difference, mm / m
ALPOLIC™ A2	19 x 10 <sup>-6</sup>	1.0 mm
ALPOLIC™ /fr	24 x 10 <sup>-6</sup>	1.2 mm
Aluminium	24 x 10 <sup>-6</sup>	1.2 mm
Concrete	12 x 10 <sup>-6</sup>	0.6 mm

### Aluminium substructure

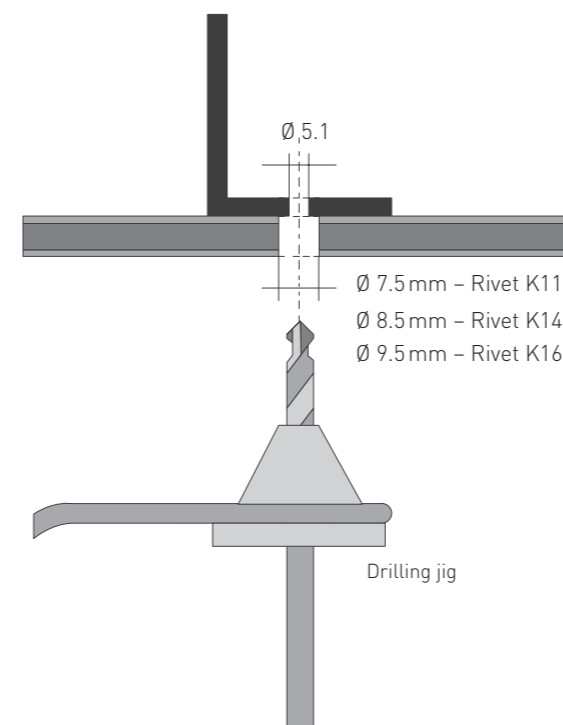

### Extreme temperature and installation temperature

In accordance with DIN 18516-1, the extreme temperatures and the installation temperatures must be used for determination of the temperature difference. Independent of the above, a reduced temperature difference of  $\Delta T = 10$  K can be used for the calculation in the direction of the substructure of aluminium profiles, if the facade panels and the substructure have a direct contact, which means that a thermal stop does not exist (see the General Construction Regulation Z-10.3-701 of DIBt, Berlin).

### Calculation example

- Expected max. temperature of ALPOLIC™ A2 80 °C
- Temperature at the installation 20 °C
- Length of the panel 2,000 mm
- The thermal expansion is calculated as follows:  
 $\Delta L = 19 \times 10^{-6} \times (80 - 20) \times 2,000 = 2.25$  mm

ALPOLIC™/fr and ALPOLIC™ A2 can be processed with common types of tools such as table saw, hand-held circular saw, vertical panel saw, Square shear or CNC.

**Circular saw blade**

An example of the suitable blade:

<b>Blade</b>	Carbide tip circular saw blade (eg. 300 mm dia.)
<b>Number of teeth</b>	80 – 100
<b>Cut width</b>	2.0 – 2.6 mm
<b>Rake angle</b>	10°

An example of the operating conditions:

<b>Spindle speed</b>	2,000 – 4,000 rpm
<b>Feed speed</b>	10 – 30 m/min.

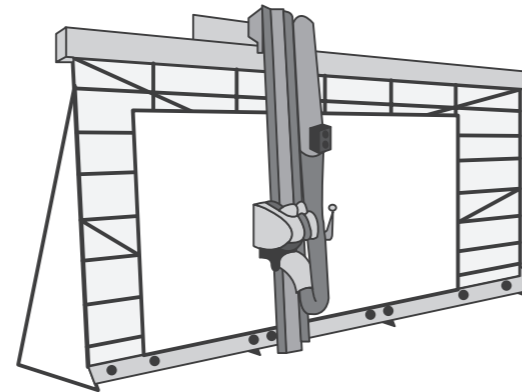

Vertical panel saw

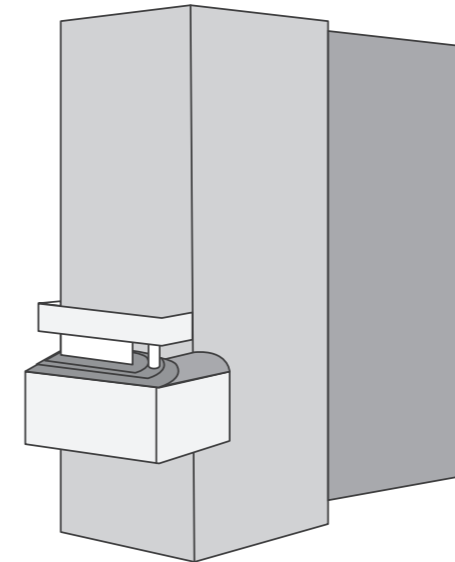

Punching press

**Trimming of cut edges**

- Three sides of the panels should be trimmed for getting more accurate rectangularity of fabricated panel.
- In case of the riveted system, all sides of the panels should be trimmed for getting more accurate rectangularity and cut edges.
- If it is possible that passers-by may hurt their fingers on the cut edges make the edges dull with fine sandpaper. Normally, droop edges by shear cutting are mild enough to ensure the safety.

**Curving cut**

Hand routers and trimmers can cut ALPOLIC™ panels in curving lines. A guide template will help you to stabilize this work. Jigsaws are also useful for cutting complex shapes.

**Notes on guide template:**

- Put the guide template on the external side of the panel, to do the routing work through the guide template.
- Remove the particles caught between the template and the panel surface, to prevent dents and scratches.

**Square shear**

An example of the suitable clearance and rake angle:

Panel thickness	Clearance	Rake angle
4 mm	0.04 – 0.1 mm	1° 30'
6 mm	0.2 mm	2° 30'

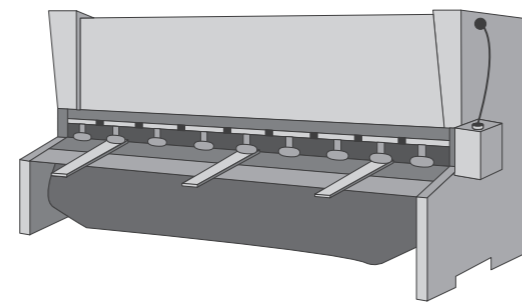

Square shear

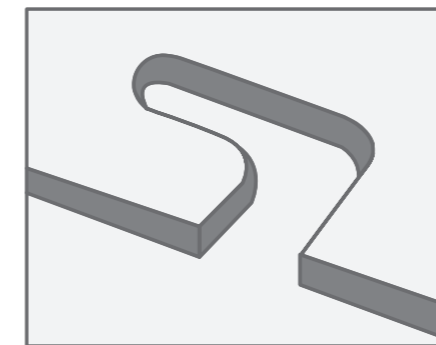

Example of punching

**Punching/notching**

- We can use a punching press for notching and cutting out, and a notching tool for removing the corner.
- The suitable clearance between punch and die is 0.1 mm or smaller (material thickness × approx. 2 %).
- A small droop will appear at the punched edge.

**Drilling**

- We can make holes with a hand drill or a drill press, equipped with a drill bit, a hole-saw and a circle cutter.
- To reduce the burr at the edge of the hole, drill the hole from the visible side.

**End-mill**

An example of the suitable end-mill and operating conditions:

<b>End-mill</b>	Square end-mill solid carbide (eg. 4 – 6 mm dia.)
<b>Spindle speed</b>	12,000 – 24,000 rpm
<b>Feed speed</b>	5 – 8 m/min.

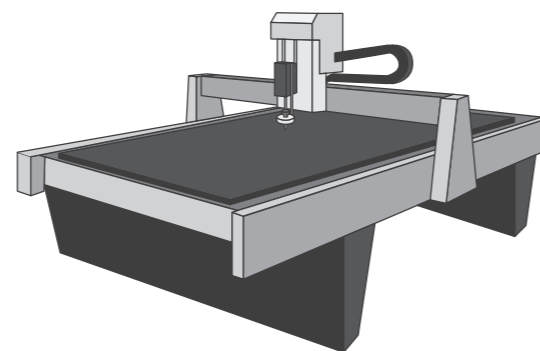

CNC machining centres

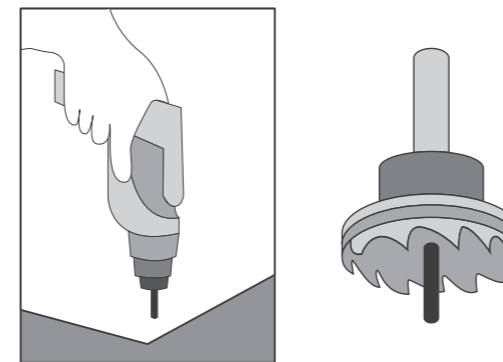

Drilling



ALPOLIC™/fr can be grooved with various types of tools such as hand grooving machines (blade), hand routers and panel saws. As for ALPOLIC™ A2, CNC is suitable.

**CNC (Suitable for ALPOLIC™/fr or ALPOLIC™ A2)**

An example of the suitable end-mill and operating conditions:

<b>Bit</b>	Carbide tip router bit
<b>Rotation</b>	12,000 – 24,000 rpm
<b>Feeding speed</b>	5 – 8 m/min.

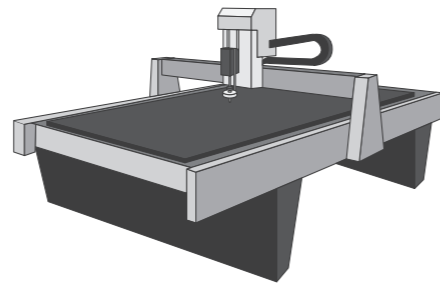

CNC machining centres

**Panel saw (Not suitable for ALPOLIC™ A2)**

An example of the suitable blade and operating conditions:

<b>Blade</b>	Carbide tip cutter blade
<b>Outside diameter</b>	220 mm
<b>Number of teeth</b>	8
<b>Rotation</b>	2,500 – 5,000 rpm
<b>Feeding speed</b>	30 m/min.

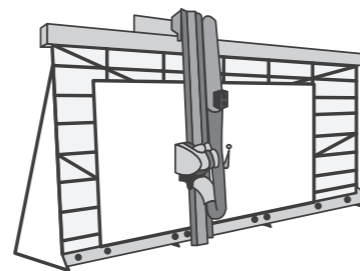

Vertical Panel saw

**Hand grooving machine (Not suitable for ALPOLIC™ A2)**

An example of the suitable blade and operating conditions:

<b>Blade</b>	Carbide tip cutter blade
<b>Outside diameter</b>	110 – 120 mm
<b>Number of teeth</b>	4
<b>Rotation</b>	5,000 – 9,000 rpm
<b>Feeding speed</b>	5 – 20 m/min.

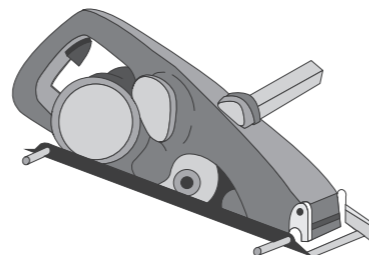

Hand grooving machine and groove cutter

**Hand router (Not suitable for ALPOLIC™ A2)**

An example of the suitable bit and operating conditions:

<b>Bit</b>	Carbide tip router bit
<b>Number of teeth</b>	2 – 4
<b>Rotation</b>	20,000 – 30,000 rpm
<b>Feeding speed</b>	3 – 5 m/min.

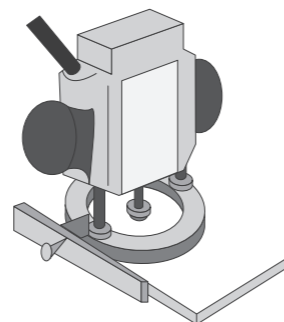

Hand router and router bit

The typical groove shape is slightly different between ALPOLIC™ A2 and ALPOLIC™/fr. The following shows the each shape which is suitable for 90° folding:

**ALPOLIC™/fr**

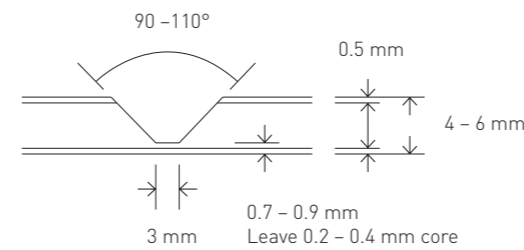

**ALPOLIC™ A2**

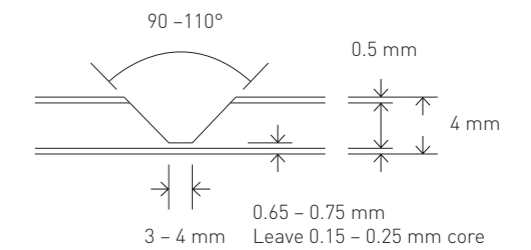

**Folding**

The following shows each typical folding procedure of ALPOLIC™ A2 and ALPOLIC™/fr:

**1. U-groove**  
Leave core as follows:  
ALPOLIC™ A2 | 0.15 – 0.25 mm  
ALPOLIC™/fr | 0.20 – 0.40 mm

**4. Roundness**  
A suitable roundness is:  
ALPOLIC™ A2 | 1.5 – 2 mm R  
ALPOLIC™/fr | 2 – 3 mm R

**2. Folding jig**  
Use a folding jig made of aluminium or steel angle or H-profile

**5. Support**  
Support with aluminium angle, if necessary.

**3. Fold**  
Folding by a jig nearly fits to the folding length.

**Notes on folding:**

- Fold the panels on a flat and stable worktable, because, if we fold a warping panel, the folding centerline will not be straight.
- The folded corner should have the suitable roundness as the above-mentioned figure. If the roundness is too small, the coating may have a crack on the folded corner. Check your U-shape and grooving depth.
- Cracks may occur when we carry out the folding work at a low temperature. Have your folding work at 10 °C or higher.
- Folding after U-grooving entails slight elongation. The elongation is 0.5 -1.0 mm per fold. Pre-adjust the position of the grooving line in your fabrication drawing.

## Bending

Roll bending is suitable for ALPOLIC™ A2 and ALPOLIC™/fr.

As for press brake, it is only available for ALPOLIC™/fr.

### Three-roll bender

Panel thickness	ALPOLIC™ A2	ALPOLIC™/fr
4 mm	600 mm R	300 mm R

### Notes on Three-roll bending

- The exact bendable limit depends on the bending roll diameter, roll length and the type of bending machine.
- Prior to a bending operation, wipe the roll surface carefully.
- Remove any burrs at the panel edge that may cause dents while rolling.
- Remove the cut particles stuck on the panels and smooth any wrinkles on the protective film, which may cause dents.
- Do not constrict the panels between rolls (in thickness direction). Extreme compression may cause a physical damage of the core. Adjust the clearance between rolls to be the panel thickness plus some allowance (approx. 0.5 mm).
- If a notch is desired in the panel, cut the notch after bending. Cutting the notch before bending will result in a distorted curving.
- Generally, small radii will need gradual bending by adjusting the elevation of the bending roll several times.
- In most 3-roll benders, the curve near the edge tends to be straight. We can reduce this straight portion to some extent by overlapping another auxiliary sheet material and bending together with ALPOLIC™ panels. If we require a consistent curve near the edge, we have to do additional edge bending after regular bending.
- When we carry out the bending work at a low temperature e.g. 15 °C and with small radius e.g. 300 mm R, the coating surface may change to a haze-like appearance. Warm the panel to 20 °C or higher, and the haze-like appearance will disappear.
- In metallic colors, slight color difference can be seen between bent and flat surfaces due to the difference of reflection angle.

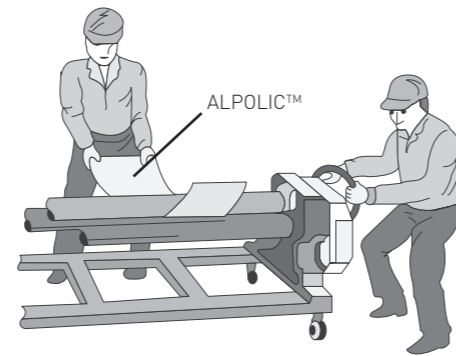

Three-roll bender

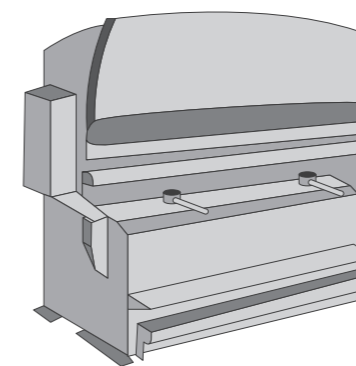
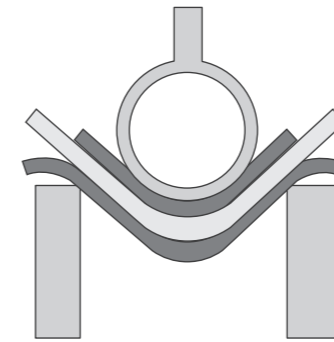
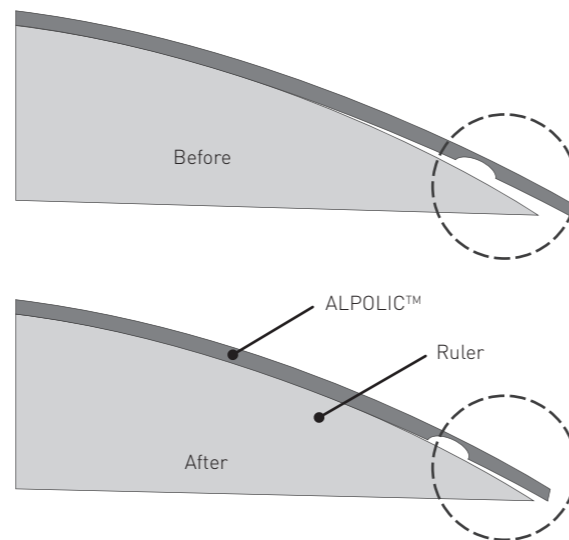

Press brake bending

### Press brake (Not suitable for ALPOLIC™ A2)

The smallest internal bendable radius of

ALPOLIC™/fr is as follows:

Thickness	Smallest bendable radius	
	600 mm R	300 mm R
4 mm	80 mm	100 mm
6 mm	100 mm	140 mm

### Notes on press brake bending

- "Transverse" and "Longitudinal" show the bending direction toward the rolling (coating) direction printed on the protective film.
- The smallest bendable radius means the limit at which visible wrinkles appear on the aluminum surface of the panel. Cracks will appear at a slightly smaller radius than this value.
- Use the top die (punch) with an almost similar radius to the desired radius. If the radius is much smaller, the bending radius partially goes beyond the above limit, and cracks may occur.
- Use a urethane pad for the bottom die, or place a rubber mat between the panel and the bottom die.
- Use a scratch-free top die. Polish and wipe the top die. Do the bending work without peeling off the protective film of the panel.
- When we carry out the bending work at a low temperature e.g. 15 °C, the coating surface may change to a haze-like appearance. Warm the panel to 20 °C or higher, and the haze-like appearance will disappear.
- In metallic colors, slight color difference can be seen between bent and flat surfaces due to the difference of reflection angle.

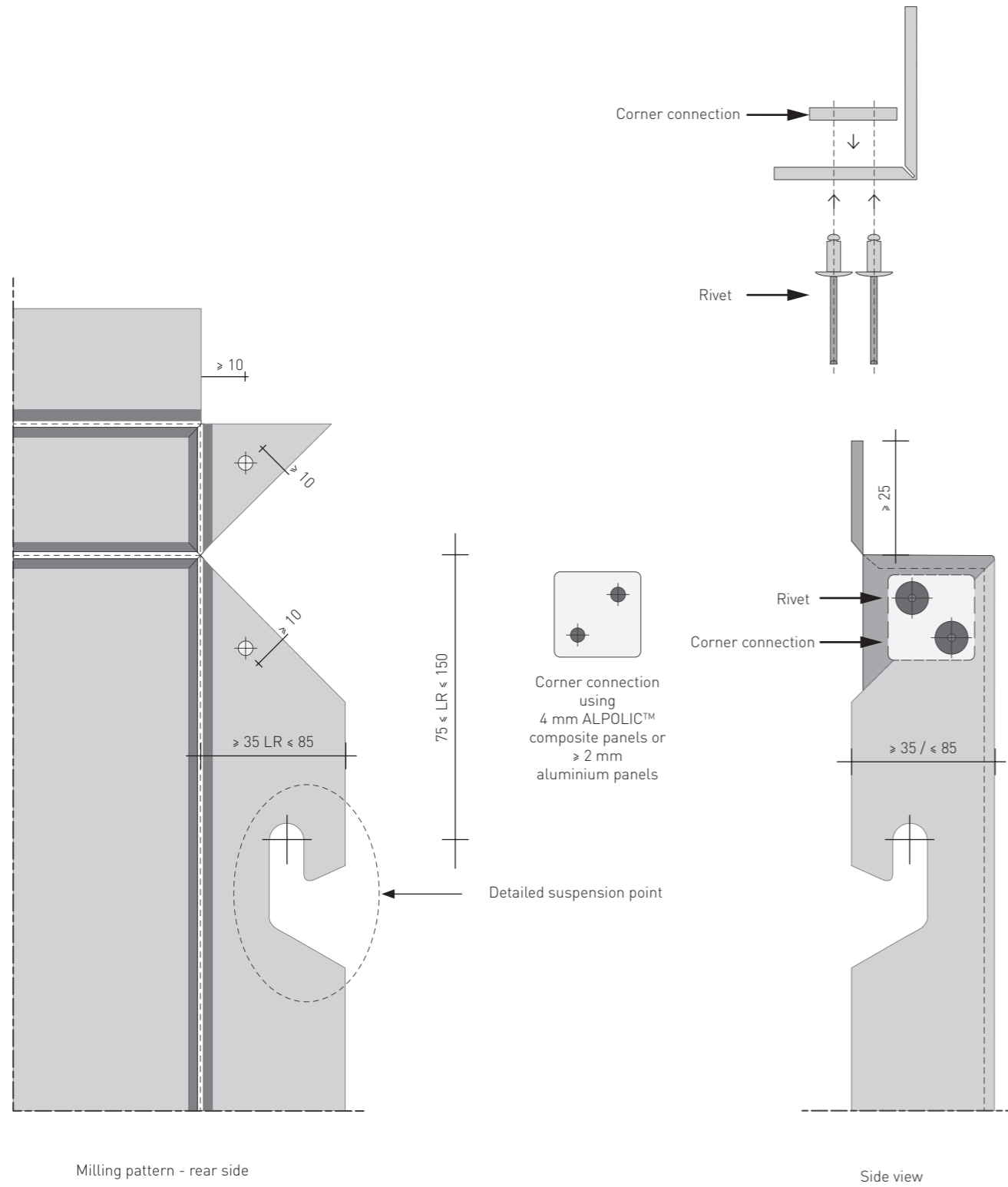

**Folding sequence**

**1. V-groove**

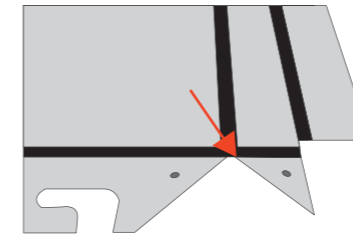

**2. Fold the narrow side more than 90°**

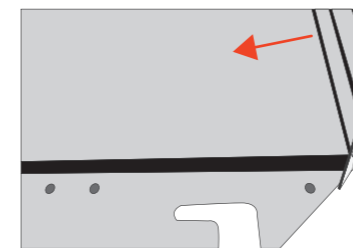

**3. Fold back to a little more than 90° and slightly fold the corner piece**

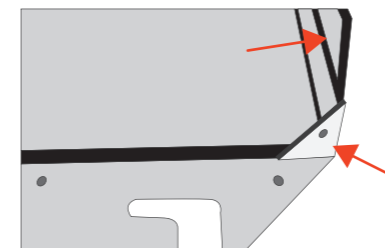

**4. Fold the Corner piece together with lengthwise edge**

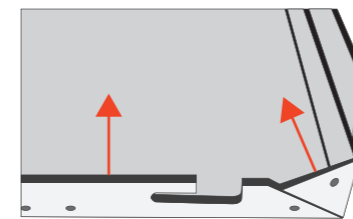

**5. Fold the opper edges**

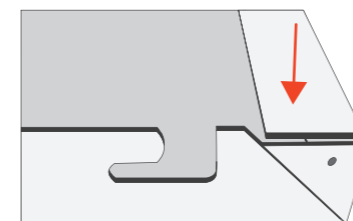

Due to the pretension when folding over the narrow side, both flanks of the V-punching have a tight fit.

You can fold the ALPOLIC™ composite panels either using a self-designed rail or a bending bank.

- Fold the composite panels on a level and stable working area to avoid warping of the panel in the centre axis.

- Carry out the folding at a temperature of min. 10 °C to avoid the formation of cracks.

Perforated panels of ALPOLIC™/fr have a pattern of holes at regular intervals. This provides ventilation and permits vision through the panel, making it suitable for balconies, staircases, partitions and ceiling. A perforation is not recommended in ALPOLIC™ A2 due to a characteristic of water permable of the core.

**1. Perforation process**

We normally use a turret puncher for perforation of ALPOLIC™/fr and ALPOLIC™ composite panels. Suitable clearance between punch and die is 0.1 mm or smaller (material thickness x 2 %). A small droop will appear at the punched edge.

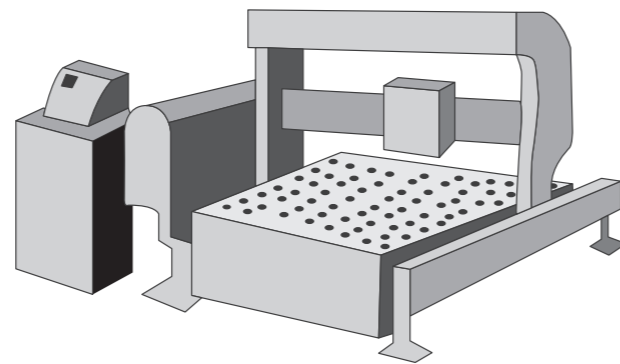

**2. Example of perforation pattern**

On the left a typical hole-arrangement of circle-shaped holes is shown.

**3. Panel strength**

Panel strength is lessened after perforation. Namely, the permissible load of ALPOLIC™ panels become smaller dependent on the perforation ratio (perforated area per total area).

Direction	Pattern	Hole diameter	Interval (W)	Perforation ratio
Square		20 mm	40 mm	19.6%
60° Zigzag		5 mm	10 mm	22.6%
		6 mm	10 mm	32.6%
		7 mm	10 mm	44.4%
		7 mm	10 mm	30.8%
		8 mm	10 mm	40.2%
		8 mm	10 mm	22.6%
		10 mm	10 mm	40.2%
15 mm	10 mm	32.6%		

Note: Perforation ratio is % of the total area that is perforated.

For professional and quality-assured cleaning, we recommend hiring a company certified according to the GRM (Quality Association for Cleaning Metal Façades).

**Removal of light surface soiling**

Generally, the following steps will enable you to remove light soiling from ALPOLIC™ surfaces.

1. Apply a water rinse with moderate pressure to dislodge the soiling. If this does not remove the soiling, test a simultaneous water rinse with a sponge. If the soiling is still adhering after dry, test a diluted mild detergent.
2. When you use a diluted mild detergent, use it with soft sponges or soft rags. Wash the surface with uniform pressure and clean the surface in a horizontal motion first and then in a vertical motion.
3. Minimize the drip and splash of the mild detergent and rinse the rundown immediately to avoid streaking. Clean the surface from top to bottom and follow with a thorough rinse with clean water.

**Caution**

- Strong solvents and strong cleaner may cause damage to the coating. Do a spot test on a small unseen area.
- Do not use household cleaners containing abrasives.
- Do not rub excessively as it may change the coating appearance.
- Avoid drips and splashes. Remove the rundown as soon as possible.
- Avoid extremely high and low temperatures.
- Do not use paint removers, strong alkali or acid cleaners. Do not use strong organic solvents such as MEK (Methyl Ethyl Ketone), MIBK (Methyl Isobutyl Ketone), Treclene (Tri-chloroethylene) or thinner.
- Make sure that cleaning sponges and rags are grit free.
- Do not mix cleaners.

**Removal of medium to heavy surface soiling**

In order to remove medium to heavy soiling caused by grease and sealing material, some type of alcohol such as IPA (Isopropyl Alcohol), ethanol or N-hexane is used. Dilute these alcohols by 50 % with water. Strong solvents or solvents-containing cleaners may have a detrimental effect on the coating surface. Do a spot test on a small unseen area. Wash the residues with mild soap and rinse with water.

The determination of suitability for use, design, fabrication, installation and interface with other products of the ALPOLIC™ materials is the sole responsibility of the purchaser. The information contained on this Technical Manual is for conceptual use only. Mitsubishi Plastics Inc. shall have no responsibility or liability for the products usage or infringement of any patent or other proprietary right.

## ALPOLIC™ International:

### MITSUBISHI CHEMICAL CORPORATION

ALPOLIC Department  
1-1-1, Marunouchi, Chiyoda-ku, Tokyo 100-8251, Japan  
phone: +81 3 6748-7348  
fax: +81 3 3286-1307  
mpi-ho-info@alpolic.jp

### MITSUBISHI CHEMICAL EURO ASIA LTD.

Bağlarbaşı Kisikli Cad., No: 4, Sarkuysan-AK İş Merkezi, S-Blok,  
Teras Kat, Altunizade, Üsküdar, 34664 Istanbul, Turkey  
phone: +90 216 651-8670/71/72  
fax: +90 216 651-8673  
info@alpolic.com.tr

### MITSUBISHI CHEMICAL ASIA PACIFIC PTE LTD.

Sales & Marketing 2 Department  
Mapletree Anson, 60 Anson Road, #10-01, Singapore 079914  
phone: +65 6226-1597  
fax: +65 6221-3373  
mpap-sg-info@alpolic.sg

### MITSUBISHI CHEMICAL COMPOSITES AMERICA, INC.

ALPOLIC Division  
401 Volvo Parkway, Chesapeake, VA 23320, USA  
phone USA: 800 422 7270  
phone international: + 1 757 382 5750  
fax: + 1 757 436 1896  
info@alpolic.com

### MITSUBISHI POLYESTER FILM GmbH

ALPOLIC Division  
Kasteler Straße 45/E512  
65203 Wiesbaden, Germany  
phone: +49 611 962-3482  
fax: +49 611 962-9059  
info@alpolic.eu  
www.alpolic.com



Quality  
made in  
Germany



#### Recycling

Our materials are almost 100 % recyclable. Even waste from ALPOLIC™ plants is collected and recycled.



ISO 9001:2015  
ISO 50001:2011  
ISO 14001:2015  
www.tuv.com  
ID: 1104310246



Trademark of AGC Chemicals,  
Asahi Glass Co., Ltd.

The material properties or data in this publication are portrayed as general information only and are not product specifications. Due to product changes, improvements and other factors, Mitsubishi Chemical Corporation reserves the right to change or withdraw information contained herein without prior notice. Care has been taken to ensure that the contents of this publication are accurate, but Mitsubishi Chemical Corporation do not accept responsibility for errors or for information that is found to be misleading.  
©2018 Mitsubishi Chemical Corporation. All rights reserved. ALPOLIC™ is a trademark of Mitsubishi Chemical Corporation.